

1 Robert Mackey
LAW OFFICES OF ROBERT MACKEY
2 16320 Murphy Road
3 Sonora, CA 95370
4 Telephone: (412) 370-9110
bobmackeyesq@aol.com

5 Nicholas A. Migliaccio *
Jason S. Rathod *
6 MIGLIACCIO & RATHOD LLP
7 412 H St. NE, Suite 302
Washington, D.C. 20002
8 Telephone: (202) 470-3520
9 Facsimile: (202) 800-2730
nmigliaccio@classlawdc.com
jrathod@classlawdc.com

10 *Attorneys for Plaintiff and the Proposed Class*

11
12
13 **UNITED STATES DISTRICT COURT**
14 **NORTHERN DISTRICT OF CALIFORNIA**
15 **OAKLAND DIVISION**

16 BO ZHANG, Individually and on Behalf of All
Others Similarly Situated,

17 Plaintiff,

18 vs.

19 IKEA US RETAIL LLC and IKEA NORTH
20 AMERICA SERVICES, LLC,

21 Defendant.

Case No.

CLASS ACTION COMPLAINT

JURY TRIAL DEMANDED

22
23
24
25 Plaintiff Bo Zhang (“Plaintiff”), individually and on behalf of all those similarly situated, files
26 this proposed class action suit against Defendant IKEA North America Services, LLC d/b/a Ikea
27 (“Ikea” or “Defendant”), based upon his personal knowledge as to facts specific to him in an
28

1 individual capacity and based upon the investigation of counsel in all other respects, and alleges as
2 follows:

3 **I. INTRODUCTION**

4 1. Ikea designs and sells ready-to-assemble furniture, kitchen appliances, home
5 decorations, home accessories, and various other home goods and services. Ikea showcases its current
6 products with floor models and in catalogues it publishes. Despite this apparent transparency as to the
7 quality of its goods or truthfulness of its advertising, Ikea has misrepresented the materials used in the
8 construction of its Hemnes Daybed and Brimnes Daybed frames (the “Class Beds”). Rather than
9 being built of solid wood, as floor models, catalogues, and website descriptions suggest, Ikea
10 constructs the Class Bed frames with comb, or finger, joints, which do not provide the same structural
11 support that a solid piece of wood does (the “Comb Joint Defect” or “Defect”).
12
13

14 2. A comb joint is used to combine two pieces of wood end to end to create longer more
15 desirable pieces from shorter lengths of wood. A single comb-jointed piece may consist of two or
16 more shorter pieces, each of which is glued together to create the illusion of a single length of wood.
17 The cross-section of the joint resembles an interlocking zig-zag pattern where the spines of one piece
18 fit into the slots of the other. The two wood pieces that form a comb joint are each individually
19 susceptible to environmental changes, particularly temperature and moisture. Varying levels of
20 ambient humidity cause the pieces of wood to contract or expand perpendicular to the directions of
21 the wood fibers, thus causing each of the spines to expand or contract across their width. With time,
22 the strength of the joint weakens and presents serious structural concerns. Comb joints are, therefore,
23 unsuitable to provide the structural support one expects when buying a bed frame described as being
24 constructed from “solid pine.”
25
26
27
28

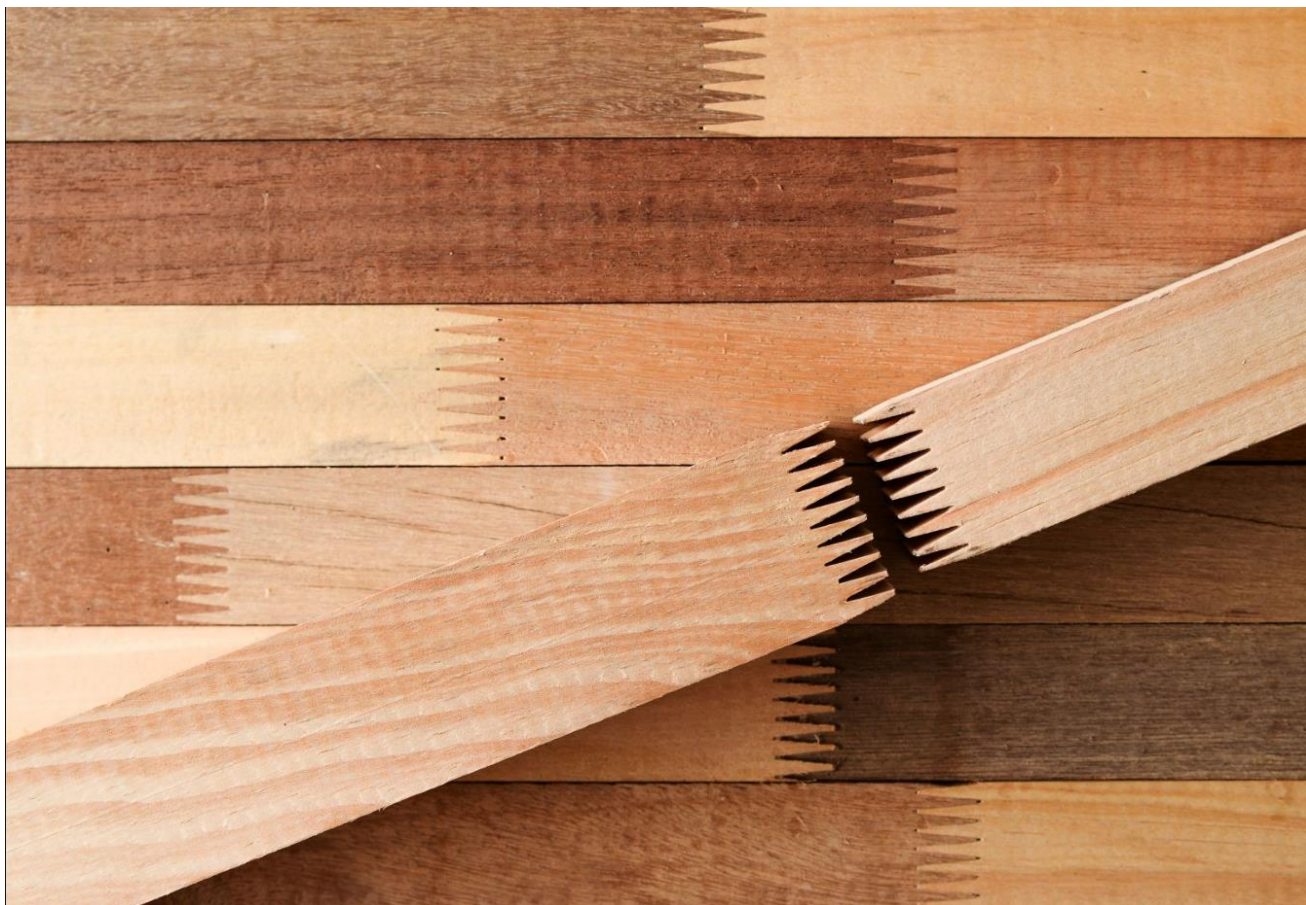

Figure 1 Comb, or finger, joints in timber.¹

3. As a result of the misrepresentation, owners of the Class Beds received a product with less structural integrity than they paid for, and rightly expected. Worse yet, because each board that makes up the bed frame is assembled using comb joints, repairs would only constitute temporary fixes because the replacement boards will ultimately fail as well.

4. Ikea knew, and/or was on notice of the fact, that its Class Beds were constructed using comb joints that combined two or more pieces of wood, rather than being one solid piece. Nevertheless, Ikea advertised the Class Beds as having a base constructed of “solid pine,” to suggest the Class Beds had the structural integrity a reasonable consumer would expect from solid wood.

¹ <https://timberco.com.ph/finger-joints-1/> (last accessed Oct. 17, 2023).

1 5. If Plaintiff and/or other Class members knew of the misrepresentation at the time of
2 purchase, they would not have bought or financed the Class Beds or would have paid substantially
3 less for them. Plaintiff and other Class members were denied the benefit of the bargain in connection
4 with their purchases or financing of the Class Beds.

5
6 6. The conduct described herein makes Defendant liable for, among other things, breach
7 of express and implied warranties, and unfair, deceptive, and/or fraudulent business practices. In turn,
8 owners and/or financiers of the Class Beds, including Plaintiff, have suffered an ascertainable loss of
9 money and/or property and/or loss in value. The unfair and deceptive trade practices committed by
10 Defendant caused Plaintiff and the Class members damages, including, but not limited to, loss of
11 value, loss of use of the Class Beds, and other replacement costs.

12
13 7. Accordingly, Plaintiff brings this action to redress Defendant's misconduct. Plaintiff
14 seeks recovery of damages under state consumer protection statutes and applicable express and
15 implied warranties, and reimbursement of all expenses associated with the repair or replacement of
16 the Class Beds.

17 **II. JURISDICTION AND VENUE**

18
19 8. This Court has subject matter jurisdiction under the Class Action Fairness Act of
20 2005, 28 U.S.C. § 1332(d)(2) and (6) because: (a) there are 100 or more class members; (b) there is
21 an aggregate amount in controversy exceeding \$5,000,000 exclusive of interest and costs; and (c)
22 there is minimal diversity because at least one plaintiff and one defendant are citizens of different
23 states.

24
25 9. Venue is proper in this judicial district under 28 U.S.C. § 1391 because Defendant
26 transacts substantial business and because Plaintiff purchased his Class Bed at issue in this District.
27 Defendant advertised in this District and received substantial revenue and profits from sales and/or
28

1 leases of the Class Beds in this District. Therefore, a substantial part of the events and/or omissions
2 giving rise to the claims occurred, in part, within this District.

3 10. This Court has personal jurisdiction over Defendant by virtue of its transactions and
4 business conducted in this judicial district. Defendant has transacted and done business, and violated
5 statutory and common law, in the State of California and in this District.
6

7 **III. PARTIES**

8 **A. Plaintiff**

9 11. Plaintiff Bo Zhang (“Plaintiff Zhang”) is a citizen of California and resides in San
10 Rafael, California.

11 **B. Defendant**

12 12. Defendant IKEA US RETAIL LLC (“IKEA Retail”) is a Virginia limited liability
13 company with a principal place of business located at 420 Alan Wood Road, Conshohocken,
14 Pennsylvania. At all times relevant to Plaintiff’s claims, IKEA Retail was and is the business entity
15 responsible for the sale, distribution and returns of the defective daybeds. The location of IKEA
16 Retail is the U.S. headquarters for the retail sales of IKEA furniture.
17

18 13. Defendant Ikea North America Services, LLC (“IKEA Services” or, collectively with
19 IKEA Retail, “Ikea”) is a Virginia limited liability company with its principal place of business
20 located at 420 Alan Wood Road, Conshohocken, Pennsylvania 19428. Ikea Services operates as a
21 subsidiary of IKEA Holdings U.S., Inc., a subsidiary of INGKA HOLDINGS B.V., a Swedish
22 company.²
23
24
25
26
27

28 ² Alternatively, IKEA Services is responsible for the above conduct in conjunction with IKEA Retail and/or IKEA Retail is solely responsible for the above conduct.

1 14. Ikea operates 51 U.S. retail locations, as well as 18 Pick-Up locations for furniture or
2 other large orders.³

3 15. Ikea may be served through its registered agent, The Corporation Trust Company,
4 located at the Corporation Trust Center, 1209 Orange Street, Wilmington, DE 19801.
5

6 **IV. SUBSTANTIVE ALLEGATIONS**

7 **A. The Class Beds**

8 16. Plaintiff purchased a “HEMNES Daybed frame with 3 drawers, gray, Twin,” or the
9 Class Bed, on September 3, 2023, for \$449, from Defendant’s store located on 4400 Shellmound
10 Street, Emeryville, California 94608. The article number in Defendant’s catalog is 204.727.01.⁴
11

12 17. Defendant’s Emeryville store is part of its network of retail locations across the United
13 States. Ikea features its Emeryville location on its website as an authorized retail location, with links
14 to lists of its inventory of Ikea products and delivery services on its website.

15 18. When shopping for his Class Bed, Plaintiff Zhang researched and considered the
16 reliability and quality of the Class Bed, including by visual inspection of the floor model. In addition,
17 Plaintiff was familiar with Ikea’s representations about the quality of its products, warranties, and
18 safety.
19

20 19. Prior to purchasing his Class Bed, Plaintiff Zhang reviewed Ikea’s promotional
21 materials on the internet, including representations that the bed slats were made out of solid wood.
22 Plaintiff Zhang also viewed the Class Bed in person prior to purchase. Each of those information
23 sources failed to disclose the misrepresentation that Plaintiff Zhang would only come to realize once
24

25
26
27

³ <https://www.ikea.com/us/en/stores/> (last accessed Oct. 11, 2023).

28 ⁴ The product may also be viewed on Defendant’s website: <https://www.ikea.com/us/en/p/hemnes-daybed-frame-with-3-drawers-gray-20472701/> (last accessed on October 6, 2023).

1 he began assembling the product himself *after* purchase. An image from the website description of
2 the Class Bed that Plaintiff purchased is excerpted below:

3
4 **Material**

5 **Leg/ Bed end filling/ Back/ Back top rail/ Drawer front
frame/ Drawer front:**

Fiberboard, Acrylic paint, Polyester paint

6 **Bed base/ Bottom rail:**

7 Solid pine

8 **Box:**

Particleboard, Melamine foil

9 **Drawer bottom:**

Fiberboard, Acrylic paint

10 **Drawer back/ Drawer sides:**

11 Particleboard, Plastic foil

12 20. Through his exposure and interaction with Ikea, Plaintiff Zhang was aware of Ikea's
13 uniform and nationwide marketing message that its products are safe and dependable, which was
14 material to his decision to purchase his Class Bed. When he purchased the Class Bed, he believed
15 that, based on Ikea's marketing message, as well as its representations of the materials used to
16 construct the Class Bed, he and his family and guests would be able to rest on a safe, sturdily
17 constructed bed. At no point before Plaintiff Zhang purchased his Class Bed did Ikea disclose to him
18 that the bed frame slats for his Class Bed were constructed from multiple pieces of wood rather than a
19 single solid piece.
20

21
22 21. After purchasing the Class Bed, Plaintiff Zhang began assembling it at his home and
23 first learned that the bed frame slats were not one piece of wood for each board, but rather multiple
24 pieces connected via comb joints. As detailed herein, comb joints provide inferior structural support
25 for the bed frame compared to the solid pieces of wood that Defendant represented on its website and
26 in its showrooms.
27
28

1 22. Ikea markets its products as “well-designed, functional, durable, affordable and
2 sustainable home furnishing solutions.”⁵ In advertising the affordability of its products, Ikea assures
3 customers that “never means compromising on quality, style, sustainability, or convenience.”⁶ In
4 addition, Ikea represents that it is “committed to customer safety,” and “want[s] our homes to be a
5 safe place[.]”⁷

7 23. Ikea’s marketing and image resonates with customers. As noted in its annual summary
8 report for the 2022 fiscal year, it “saw a slight increase in total sales despite persistent supply changes
9 and rising inflation[,]” which resulted in a total sales figure over \$5.9 billion.⁸

10 24. The company, however, is no stranger to product recalls. Indeed, it currently lists 55
11 recall notices on its website, which includes expanded recalls, and recalls for multiple products in the
12 same class, such as a variety of dressers and chests that present serious tip-over hazards.⁹

14 25. The Class Beds are currently available for purchase on Ikea’s website, for \$449.00.
15 The Class Beds are described as “[a] sofa, a single bed, a double bed and storage in one piece of
16 furniture! Perfect if you are tight on space.” In the “Materials & care” section of the page’s “Product
17 details,” the bed base material is said to be of “Solid pine.” As Ikea’s marketing images and
18 instruction guide show, the wood pieces used to show the base of the Class Beds is missing the
19 telltale interlocking pattern that is indicative of comb, or finger, joints. These images suggest that
20 each wood board that makes up the Class Beds’ base is one solid piece, rather than the conjoint of
21 two or more pieces.

22
23
24
25
26

⁵ <https://www.ikea.com/us/en/this-is-ikea/about-us/the-ikea-vision-and-values-pub9aa779d0> (last accessed Oct. 11, 2023).

27 ⁶ https://www.ikea.com/us/en/files/pdf/31/8a/318a75d4/us_annual_summary_fy22.pdf (last accessed Oct. 11, 2023).

28 ⁷ *Id.*, at 8.

⁸ *Id.*, at 26.

⁹ <https://www.ikea.com/us/en/customer-service/product-support/recalls/> (last accessed Oct. 11, 2023).

1
2
3
4
5
6
7
8
9
10
11
12
13
14
15
16
17
18
19
20
21
22
23
24
25
26
27
28



1
2
3
4
5
6
7
8
9
10
11
12
13
14
15
16
17
18
19
20
21
22
23
24
25
26
27
28

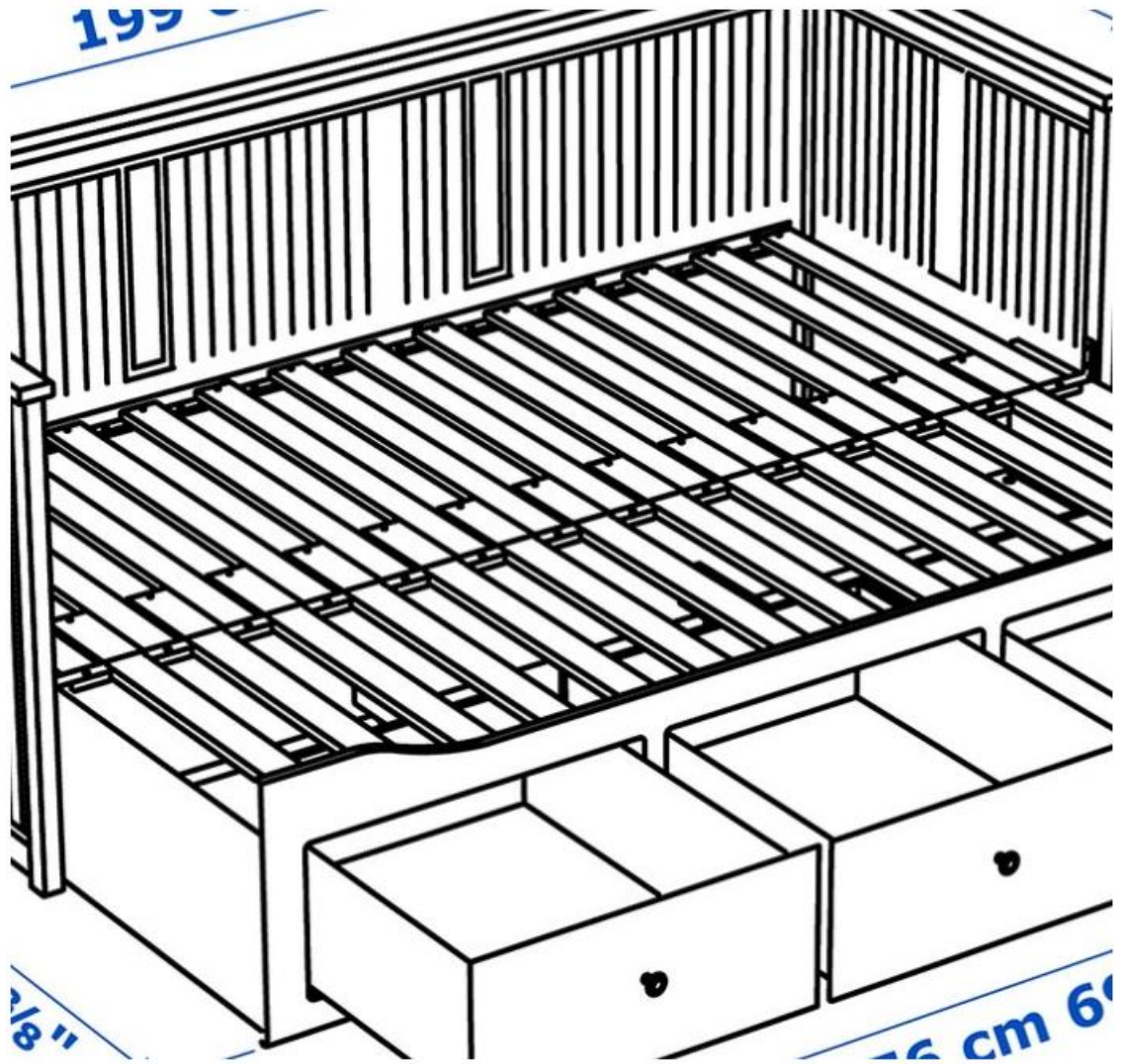

1
2 **20**

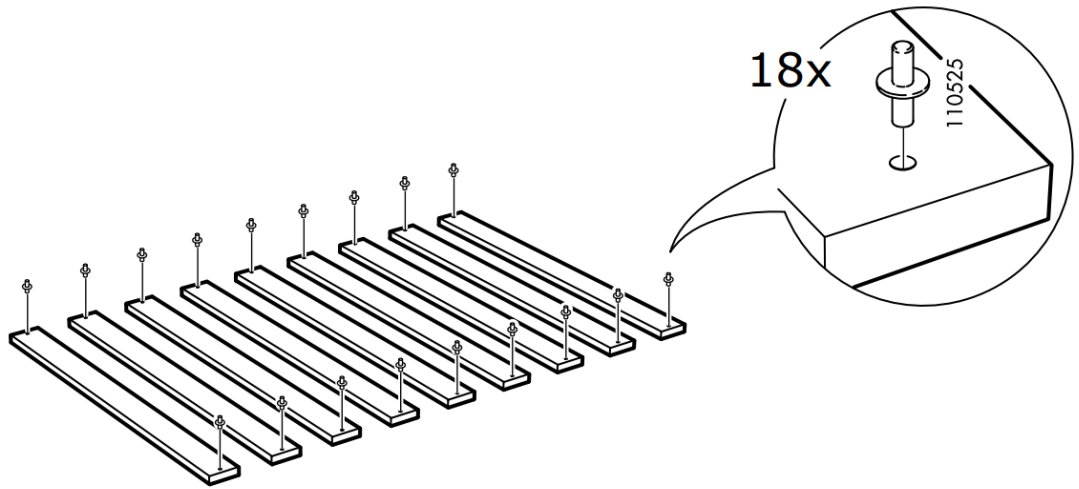

12 **9**

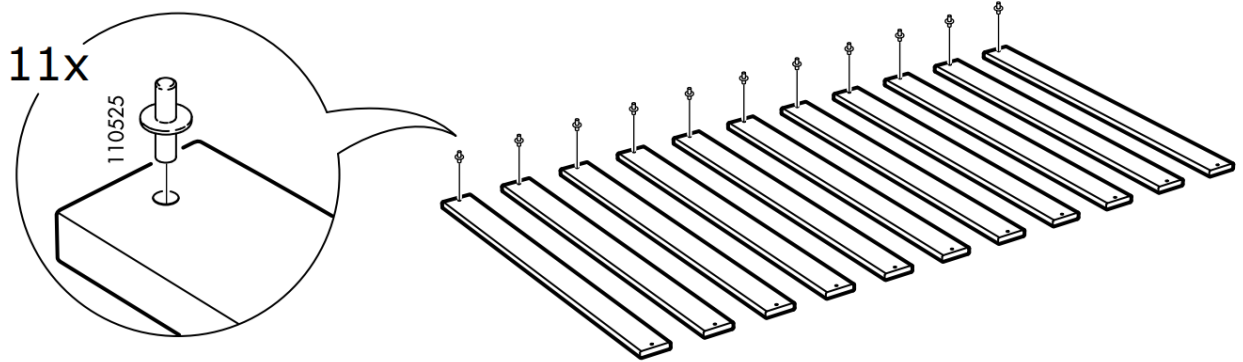

1
2 **10**

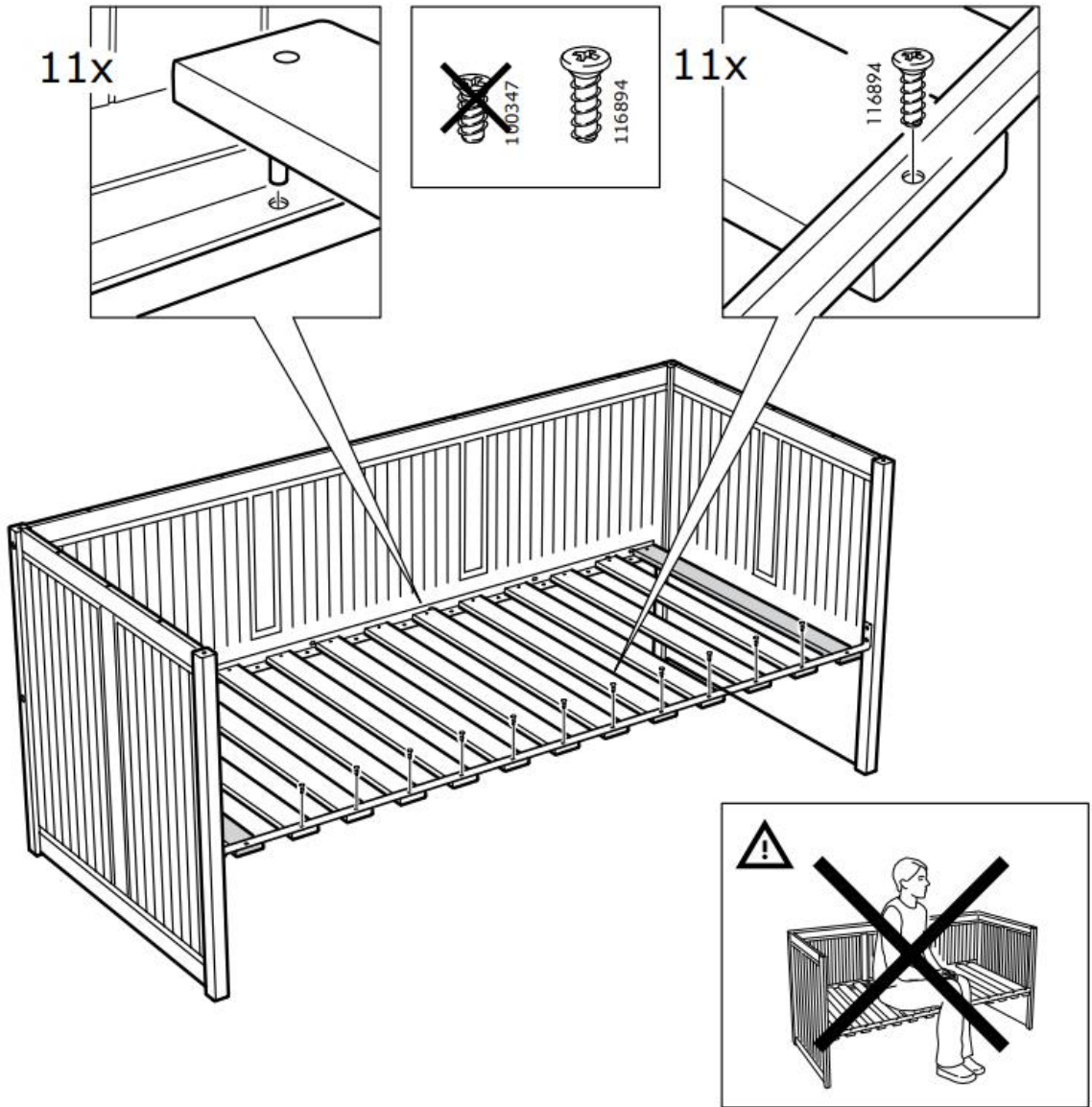

22 26. The reality of the Class Beds' base is very different. Rather than each board that
23 makes up the Class Beds' base being made of one solid wood piece, they are actually made of two or
24 more wood pieces joined together with comb joints as illustrated below:
25
26
27
28

1
2
3
4
5
6
7
8
9
10
11
12
13
14
15
16
17
18
19
20
21
22
23
24
25
26
27
28

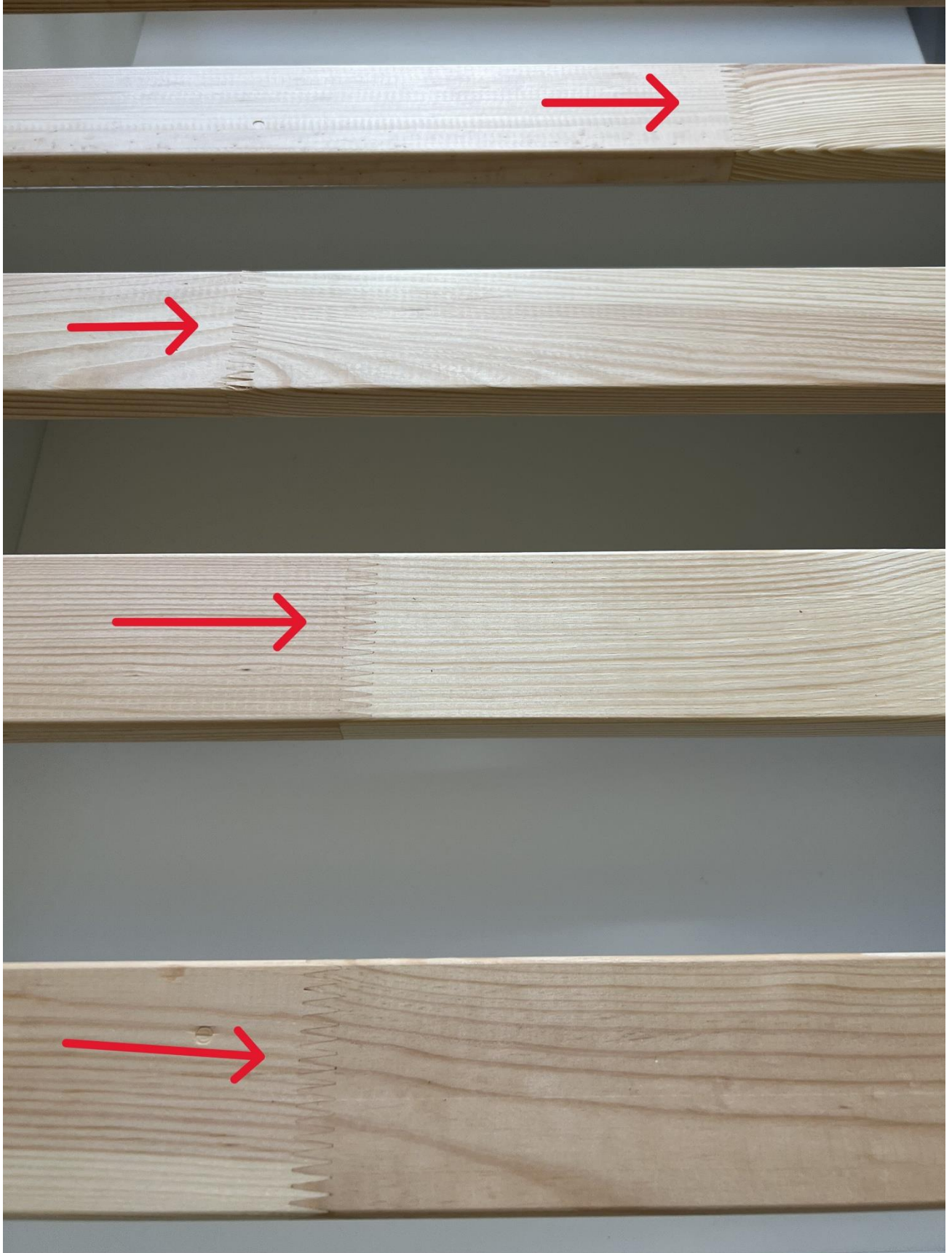

1
2
3
4
5
6
7
8
9
10
11
12
13
14
15
16
17
18
19
20
21
22
23
24
25
26
27
28



1 27. As the preceding images show, the wood board pieces that make up the Class Beds'
2 base are made up of two or more separate wood pieces joined together as one through the use of
3 comb joints. The safety and structural risks that follow from normal fluctuations in ambient
4 temperature and moisture only increase when more of these joints are present as there are more points
5 along the board where these changes could affect the structural integrity of the board, and by
6 extension, of the Class Beds.
7

8 28. Despite Ikea's representations, the Class Beds suffer from a defect that presents
9 serious structural and safety risks to anyone resting on the Class Bed.
10

11 29. Defendant actively concealed the existence and nature of the defect in the Class Beds
12 from Plaintiff and Class members. Specifically, Defendant failed to disclose or actively concealed at
13 and after the time of purchase:

- 14 a. Any and all known material defects or material nonconformity of the Class Beds,
15 including the defect pertaining to the Class Beds' base;
- 16 b. That the Class Beds, including the material used in its base, were not made with the
17 material represented, were defective, and were not fit for their intended purposes; and
- 18 c. That Defendant knew of the defect.

19 30. It was possible for Ikea to disclose the defect in multiple ways that would have made
20 the information available to reasonable consumers, such as through their sales and marketing
21 materials, catalogs, product descriptions, through sales representatives, and elsewhere. But instead of
22 notifying the public, Ikea concealed this material information from Plaintiff and other similarly
23 situated consumers and continues to sell its bed.
24

25 31. As a consequence of Ikea's actions and inactions, Class Bed owners have been
26 deprived of the benefit of the bargain, lost use of the Class Beds, been exposed to dangerous
27
28

1 conditions from the diminished structural integrity that comb joints provide, and incurred lost time
2 assembling the Class Beds. The Class Beds have suffered a diminution in value due to the defect.

3 32. Had Plaintiff and the Class members known about the defect, they would not have
4 purchased or financed the Class Beds or would have paid significantly less in doing so.
5

6 **B. Defendant has Unjustly Retained a Substantial Benefit**

7 33. On information and belief, Plaintiff alleges that Defendant unlawfully failed to
8 disclose the alleged defect to induce them and other putative Class members to purchase or finance
9 the Class Beds.

10 34. Plaintiff further alleges that Defendant thus engaged in deceptive acts or practices
11 pertaining to all transactions involving the Class Beds, including Plaintiff's.
12

13 35. As discussed above, Plaintiff alleges that Defendant unlawfully induced him to
14 purchase the Class Bed by concealing and/or omitting a material fact (*i.e.*, the defect) and that
15 Plaintiff would have paid less for the Class Bed, or not purchased it at all, had he known of the
16 defect.
17

18 36. Accordingly, Defendant's ill-gotten gains, benefits accrued in the form of increased
19 sales and profits resulting from the material concealment and omissions that deceive consumers,
20 should be disgorged.

21 37. Product reviews on Defendant's website demonstrate that Defendant was aware of the
22 Defect but chose to deny its existence or otherwise remedy it.
23

24 38. The following sampling of reviews concerning the Class Beds demonstrates the
25 manifestation of the Defect, the safety risk the Defect poses, and the Defendant's unwillingness to
26 remedy the defect.
27

28 **IKEA Hemnes Daybed Frame**

1
2
3
4
5
6
7
8
9
10
11
12
13
14
15
16
17
18
19
20
21
22
23
24
25
26
27
28

Not solid wood

09/27/2023

★☆☆☆☆

Nicolle I. - USA

Very disappointed in this product. Being a hemnes product I was expecting solid pine. However the majority of the bed is made out of particle board. Very flimsy and can't be moved without taking the bed apart. Bought this for my 1yo granddaughter so it should last a little while but would not trust it for an adult. I especially would not trust it with the bed extended to the king size with 1 adult let alone 2 full size adults. It takes hours to assemble and none of the parts are in corresponding boxes. Parts for step 1 are in box number 4 and so on. Takes an hour just to sort pieces and parts. You need a huge room to sort parts and build and you better build it where you want it or good luck moving it. Bottom bed front with drawers doesn't sit flush.

Response from IKEA:

09/27/2023 - USA

Thanks for taking the time to leave us a review. We're sorry to hear about the trouble you've experienced with this item. Whenever there is a quality concern with an assembled item, we recommend visiting our Returns Desk within 180 days of the purchase date, along with your receipt or order confirmation — to get a quality inspection of the product. We hope this helps!





1
2
3
4
5
6
7
8
9
10
11
12
13
14
15
16
17
18
19
20
21
22
23
24
25
26
27
28

Fell apart after less than 2 years 11/01/2023

★☆☆☆☆ Sara - USA

I made it per the instructions and the particle board that holds up the bed split and collapsed after a little over a year. A huge waste of money and Ikea refused to rectify this situation.

✗ No, I don't recommend this product

Ease of assembly/installation		2
Value for money		1
Product quality		1
Appearance		5
Works as expected		1

Helpful?  0

Response from IKEA:

11/02/2023 - USA

Thanks for issuing your review. Due to the date of purchase being pass 180 days, we recommend returning it to your local IKEA for further discussion of any possible alternative resolution. We hope this helps!

1
2
3
4
5
6
7
8
9
10
11
12
13
14
15
16
17
18
19
20
21
22
23
24
25
26
27
28

Beautiful design, great concept but execution was poor. Serious design flaws led to various structural failures. 08/22/2023

★☆☆☆☆ LISA S. - USA

Bed purchased Dec 2020. In Jan 2020 had to request numerous replacement parts. Including, bent supports for the slats above the drawers, bent drawer rails, screws, the large 'wood' piece on the back of the trundle. It took months due to supply chain issues to get the parts! Once we received the parts in late 2021 we fixed the bed. Here we are in mid 2023 and I find out the bed had failed AGAIN in the same as before!! My kid held it up using books! A weakness b/n the 2 mattresses when the bed is fully extended. The screws are too short and the wood too fragile to support a normal teen girl. The bed is basically useless to us at this point. Additionally it can not be sold on the second hand market because the damage is not repairable without great expense. The bed is beautiful in the catalog and on the showroom floor. Had such high hopes for this piece of furniture. Unfortunately it failed on all counts for us. Ikea needs to seriously re-evaluate the design.

Response from IKEA:
08/23/2023 - USA

Thanks for reviewing our HEMNES daybed. We're sorry to hear about the difficulties and we'll be sure to share your feedback with our sales leaders for internal review and future design improvements.

Don't buy this 08/05/2023

★☆☆☆☆ Amina A. - Canada

I don't understand why it is so expensive while it is not made from real wood. It is broken easily and I strayed to glue and add screws to fix it pleas look at the market Facebook and see the conditions of this used bed of this kind. It's function and design should only work with the real wood material not a compact one. Throwing the money in the garbage.

1
2
3
4
5
6
7
8
9
10
11
12
13
14
15
16
17
18
19
20
21
22
23
24
25
26
27
28

Way too flimsy for adults

11/02/2022

★☆☆☆☆

John J. - USA

I'm not usually one to give one star reviews, but this day bed is way too poorly designed to deserve anything higher. It looks nice and was much easier to assemble than other reviews led me to believe, but one of the wood slats snapped in half THE VERY FIRST TIME I sat on it (with a 3" mattress). I'm 6'0, 190 lb., So I'm not the smallest person in the world, but I'm also far from the biggest. And I don't think it's unreasonable to expect a bed to handle someone under 200 lb. simply sitting on it. I'll admit the bed is a lot stronger when pushed together because the slats interweave to double their strength, but God help you if you have to pull out the bottom section. It was while sitting on the pull-out that the wood snapped for me. In a nutshell, the fact that there is no extra support for those flimsy slats makes this bed unusable for adults (and probably kids too since they like to jump and bounce around). Just an all around terrible product.

✘ No, I don't recommend this product

Response from IKEA:

11/03/2022 - USA





Thanks for taking the time to review our HEMNES daybed frame. We're sorry to hear about the trouble you've experienced with this item. Whenever there is a quality concern with an assembled item, we recommend visiting our Returns Desk within 180 days of the purchase date, along with your receipt or order confirmation — to get a quality inspection of the product. We hope this helps!

1
2
3
4
5
6
7
8
9
10
11
12
13
14
15
16
17
18
19
20
21
22
23
24
25
26
27
28

Bought this bed for my son 07/27/2022

★☆☆☆☆ Chanel R. - USA

I got this for my son and when my niece and nephew come over they can sleep on the bed open. Immediately after having it it broke. We tried fixing it a million times and it will always break. This bed is terrible. I will never suggest anyone to but this. Keep in mind my son is BARELY EVER IN HIS ROOM AND HE SLEEPS WITH ME. He is four years old. So he doesn't jump on this or anything. It's terrible. Also the mattresses that it advertises are terrible as well they are super duper hard

Ease of assembly/installation		3
Value for money		1
Product quality		1
Appearance		5
Works as expected		1

Helpful?  1

Response from IKEA:
07/27/2022 - USA

Thanks for taking the time to review our HEMNES daybed frame. We're sorry to hear about the trouble you've experienced with this item. Whenever there is a quality concern with an assembled item, we recommend visiting our Returns Desk within 180 days of the purchase date, along with your receipt or order confirmation — to get a quality inspection of the product. We hope this helps!

Would not recommend - need a new bed after 6 months 05/28/2022

★☆☆☆☆ Ann-Marie D. - USA

Overall this was a terrible time putting together - it took so long. After a month an a half of sleep on it as a pull out queen the supports on the pull out part comepletely pulled out and the metal support was off the lower box. After a few months more of sleeping on it as a twin because i did not hear back from IKEA after being told they would open a ticket for me, the slats on the twin part of the bed are breaking now. I'm moving this month and this bed won't make the cut. It's a shame but it's just not worth moving. My back has been killing me and while I will still be living in a studio, I just can't justify using this low quality bed that I spent \$600+ on!

1
2
3
4
5
6
7
8
9
10
11
12
13
14
15
16
17
18
19
20
21
22
23
24
25
26
27
28

Response from IKEA:

05/29/2022 - USA

Thanks for taking the time to review our HEMNES daybed frame. We're sorry to hear about the trouble you've experienced with this item. Whenever there is a quality concern with an assembled item, we recommend visiting our Returns Desk within 180 days of the purchase date, along with your receipt or order confirmation — to get a quality inspection of the product. We hope this helps!

AWFUL. JUST AWFUL. MUST RETHINK BEFORE BUYING. 07/19/2020

★☆☆☆☆

tina777sbdjb - USA

I bought this back in March. This is only my fifth month using this bed. The instructions to make this bed took us days, it was so difficult and some of the instructions were wrong. We had to take the bed apart to change the flooring one time, and wooden pieces of the bed fell out, and from time to time it always needed to be pushed back in order to keep the drawers in balance without falling out. Everything is made of cheap material, although the price above is may be different, we got it for a total of \$600 plus tax. Today, I am tired of this bed and we just had to move this bed a little to the other side of the room and the one corner of the wooden stand ripped. Completely fake wood, cheap material and definitely only a ONE TIME USE bed before it breaks!!!!!! Terrible!!!!!!!!!!

No, I don't recommend this product

1
2
3
4
5
6
7
8
9
10
11
12
13
14
15
16
17
18
19
20
21
22
23
24
25
26
27
28

Such a disappointment

07/04/2020

★☆☆☆☆

3mammabear - Canada

The bed is so squeaky i hear my daughter's every movement. The bed was expanded for a sleepover and the mainbed wasn't able to support my daughter's weight of 85lbs and the mattress five slates became detached from the screws. We fixed and it and it immediately broke again. Also, it's very hard to expand the bed. It takes two people and alot of frustration.

✘ No, I don't recommend this product

Ease of assembly/installation		2
Value for money		2
Product quality		1
Appearance		3
Works as expected		1

Helpful? 7

Response from IKEA:

08/28/2020 - Canada

Thanks for sharing your feedback with us. At IKEA, we believe you should always be able to trust that our products are well designed, customer friendly, functional and durable. In turn, if you are not entirely satisfied with the product, we invite you to return it at your local IKEA store with your sales receipt for an inspection. If a quality issue is deemed, we will either proceed with an exchange or refund onto an IKEA gift card. On a separate note, we would like to inform you that we have shared your feedback to the concerned department for future development. We hope this helps!

1
2
3
4
5
6
7
8
9
10
11
12
13
14
15
16
17
18
19
20
21
22
23
24
25
26
27
28

Very cheaply constructed

04/02/2020

★☆☆☆☆

Thom22 - USA

I bought this bed in February 2020 for my 11 year old daughter. After spending over 2 hours putting it together we get down to the final parts only to find we were missing 8 screws. I had to drive almost 2 hours to the nearest store just to get the missing screws! Two days after being complete the bottom main support slate broke off because the supplied screws aren't long enough and the metal piece it connects to are cheap and flimsy. Then a day later the top main support slate broke the same way. Here it is April and I still have not received the replacement parts! Don't waste your money you will regret this purchase!

No, I don't recommend this product

Ease of assembly/installation	<input type="radio"/>	1
Value for money	<input type="radio"/>	1
Product quality	<input type="radio"/>	1
Appearance	<input type="radio"/>	1
Works as expected	<input type="radio"/>	1

Helpful?  21

Response from IKEA:

04/05/2020 - USA

We're sorry to hear about the difficulties you're experiencing with this HEMNES daybed. We're sending you an email requesting more information so we can help get this resolved!

1
2
3
4
5
6
7
8
9
10
11
12
13
14
15
16
17
18
19
20
21
22
23
24
25
26
27
28

Product is a safety hazard





01/01/2020

★☆☆☆☆

Karthic N - USA

Product is not suitable for adults don't be fooled by the functionality and design. My visiting parents and inlaws 50&60 years old got a back ache from sleeping on the bed not enough support. The more alarming point is that the slats break so easily. Two slats have broken on the bed as of date does not support weight. You either put a thicker mattress on top which kills the design principle of using it as a daybed or put thin beds and open yourself to fall or back pains. Disappointed we really like Ikea and when we moved here did all our shopping with them. Only purchase I wish we did not do.

✘ No, I don't recommend this product

Ease of assembly/installation		3
Value for money		2
Product quality		1
Appearance		5
Works as expected		1

Helpful?  27

Response from IKEA:

01/07/2020 - USA

Thanks for taking the time to review our HEMNES daybed. We place high value on the safety of our customers and products, so we'd like to document your feedback for our sales and manufacturing teams. Please look out for an email from us soon, as we'll need information about your purchase to proceed with documentation.





1
2
3
4
5
6
7
8
9
10
11
12
13
14
15
16
17
18
19
20
21
22
23
24
25
26
27
28

Bad quality and very Easy break 12/12/2019

★☆☆☆☆ Charlotte 5 - USA

I'm only 120 lbs, just sand up on the bed. And it broke..... I don't understand.... there is a limit on weight it can take ?

✘ No, I don't recommend this product

- Ease of assembly/installation  5
- Value for money  1
- Product quality  1
- Appearance  5
- Works as expected  3

Helpful?  25

Response from IKEA:

12/15/2019 - USA

Thank you for bringing this issue to our attention. We place high value on the safety of our customers and products, and we want to make sure your experience is documented as accurately as possible. Please check your inbox for an e-mail from us requesting more information about this item.

Terrible Product 12/03/2019

★☆☆☆☆ Dontbuythisproduct - USA

I bought this two days ago and it is horrific. If it wasn't such a pain to take apart (which actually it isn't because the slates fall when you sit on the bed) then I would return this. The included instructions are not helpful. The pieces included are terrible quality. I could not be more upset and displeased.

✘ No, I don't recommend this product

1
2
3
4
5
6
7
8
9
10
11
12
13
14
15
16
17
18
19
20
21
22
23
24
25
26
27
28

Looks good on paper, but poor construction 10/17/2019

★☆☆☆☆

Alan42 - USA

I had great expectations for this addition to our spare bedroom, but it had cheap construction; the slates did not have the correct bore for the screws and did not secure properly and they did not include enough anyway. A special trip to the hardware store was required - a bad decision on my part. You may want to consider a piece of plywood over slats if you really want to buy this,

No, I don't recommend this product

Unsafe and truly low quality! 07/23/2019

★☆☆☆☆

bbcosta - USA

The assembly of this bed is not a very pleasant experience. But the most important is how bad its construction is. The first time we used as a double bed it broke, with my 11 year old on it. He could definitely get hurt, luckily nothing happened. I returned it within 2 weeks another hassle. Pretty bad experience!

No, I don't recommend this product

1
2
3
4
5
6
7
8
9
10
11
12
13
14
15
16
17
18
19
20
21
22
23
24
25
26
27
28

It broke and customer service was a nightmare... 05/14/2019

★☆☆☆☆ AdotJdot - USA

I bought this bed about a year ago from ikea.com. They say you can pick when the item is delivered, but the window is a week long! It was difficult to assemble but a feasible challenge for my boyfriend and I. The instructions are not so great, so I suggest reading a few times before and during attempts. When we finally got it assembled, it seemed like it would fit our needs and looked pretty nice with our other decor. But then it broke. After only a few months of use, it broke when I was getting in bed. The metal part that attaches to the (composite) side wall split and tore off. This bed is a great idea, but not well executed. When I called customer service to return (within the 1-year period), I was berated and shuffled between many IKEA reps. It was like how dare I want a refund for their broken product that was still under warranty! It was quite draining even despite the fact I had nothing to sleep on. Days after my request, I was told I would be refunded for the bed but not shipping. If I wanted to replace the bed, I'd have to pay another \$200 for shipping. For that kind of money and hassle, you're better off paying a little more for a quality piece of furniture with free shipping and decent customer service.

✘ No, I don't recommend this product

Response from IKEA:

05/16/2019 - USA

Thanks for reaching out! We'd like to discuss this issue with you further. Look out for an email from us soon!

1
2
3
4
5
6
7
8
9
10
11
12
13
14
15
16
17
18
19
20
21
22
23
24
25
26
27
28

Please do not buy this bed

03/17/2019

★☆☆☆☆

mjtuttle - USA

Purchased this bed because I have seen it styled so nicely, and seemed super functional to close when not in use. If you are more than 80 pounds, you cannot use this bed as a guest bed. They should put that it's only made for children, but they don't. The metal frame supporting the second mattress came off of the screws pulling the screws from the *particle board* wood, and widened the holes. We have attempted to fix, but it will not support the second mattress nor a human being. Especially scary because it came out WHILE sleeping. So dangerous, because someone could've been injured. Called customer service and they said unless it has a warranty there is nothing they can do. I've never had to purchase a warranty before, I have a dresser from 7 years ago. So disappointing because this bed is 300 dollars and we purchased corresponding twin mattresses to accomodate the bed.

No, I don't recommend this product

Response from IKEA:

04/03/2019 - USA

Thanks for bringing the issues you've experienced with our HEMNES daybed frame to our attention. We place high value on the safety of our customers and products, and we want to make sure your experience with this product is documented as accurately as possible. Please check your e-mail for a message from us requesting more details about the incident.

1
2
3
4
5
6
7
8
9
10
11
12
13
14
15
16
17
18
19
20
21
22
23
24
25
26
27
28

Poor quality

01/09/2019



Verified Buyer - Canada

This bed took hours to assemble and the wood was cracking and fracturing in the process. I doubt it will last long as the material it is made with is so cheap. Would not recommend.

No, I don't recommend this product

1
2
3
4
5
6
7
8
9
10
11
12
13
14
15
16
17
18
19
20
21
22
23
24
25
26
27
28

Not a great bed, too delicate

03/05/2018



IkeaFan1508 - Canada

I bought this bed, not a good product at all. It is too delicate. The slats of the bed break very easily. I do nit recommend this bed to anyone

✘ No, I don't recommend this product

Value for money	<input type="radio"/>	1
Product quality	<input type="radio"/>	1
Appearance	<input checked="" type="radio"/> <input type="radio"/> <input type="radio"/> <input type="radio"/> <input type="radio"/>	4
Works as expected	<input type="radio"/>	1

Helpful? 24

Response from IKEA:

03/05/2018 - Canada

We regret to hear about this experience. We've sent you an email requesting more details. We'd like to do our best to make this right!

1
2
3
4
5
6
7
8
9
10
11
12
13
14
15
16
17
18
19
20
21
22
23
24
25
26
27
28

Very low quality

12/12/2017

★☆☆☆☆

al74 - USA

Bought the bed in store about two year ago. The bed is located in our rarely used guest bedroom and we had guests sleep on the bed in 3 occasions since we bought it. After two days of sleeping three of the wooden boards on which the mattresses are resting were broken. Since this was within the first year after purchase Ikea was nice enough to send us replacement boards. Last month the in-laws came to visit and spend few days sleeping on the bed. Now two boards are broken again and Ikea is refusing to assist in providing replacement since is after the initial year. I can't imagine this bed being used on a regular basis.

No, I don't recommend this product

39. Additionally, Defendant

40.

41. Defendant was on notice of the Defect as alleged above. Additionally, on or about October 25, 2023, Plaintiff sent a pre-suit notice and demand letter which Defendant has not responded to.

V. CLASS ALLEGATIONS

42. Plaintiff brings this action on behalf of himself, and on behalf of the following nationwide class pursuant to Fed. R. Civ. P. 23(a), 23(b)(2), and/or 23(b)(3). Specifically, the nationwide class consists of the following:

Nationwide Class

All persons or entities in the United States who are current or former owners and/or financiers of a Class Bed (the “Nationwide Class”).

1 43. In the alternative to the Nationwide Class, and pursuant to Fed. R. Civ. P. 23(c)(5),
2 Plaintiff Zhang seeks to represent the following state subclass only in the event that the Court
3 declines to certify the Nationwide Class above:

4 **California Subclass**

5 All persons or entities in California who are current or former owners and/or financiers of a
6 Class Bed (the “California Class”).

7 44. The Nationwide Class and the California Subclass are referred to herein as the
8 “Class.” Plaintiff reserves the right to modify, change, or expand the definitions of the Class based
9 upon discovery and further investigation.

10 45. The Class excludes the following: Defendants, its affiliates, and its current and former
11 employees, officers and directors, and the Judge assigned to this case. Also excluded are any current
12 or former owners or financiers of Class Beds with personal injury claims related to the defect.

13 46. *Numerosity:* The Class is so numerous that joinder of all members is impracticable. At
14 least hundreds of thousands of Class members have been subjected to Defendants’ conduct. The class
15 is ascertainable by reference to records in the possession of Ikea.

16 47. *Predominance:* Common questions of law and fact exist as to all members of the
17 Class. These questions predominate over questions affecting individual members of the Class and
18 include:
19

- 20 include:
- 21 a. Whether the Class Beds were sold with a defect;
 - 22 b. Whether Defendant knew of the Defect at the time of sale;
 - 23 c. Whether Defendant failed to disclose the defect;
 - 24 d. Whether Defendant actively concealed the defect;
 - 25 e. Whether a reasonable consumer would consider the Defect or its manifestation to be
26 material;
 - 27
 - 28

- 1 f. Whether Defendant breached express and/or implied warranties;
- 2 g. Whether Defendant must disclose the defect;
- 3 h. Whether Defendant violated consumer protection statutes and other claims asserted
- 4 herein; and
- 5 i. Whether Defendant retained an unjust benefit due to its conduct.
- 6

7 48. *Typicality*: Plaintiff's claims are typical of the claims of the members of the Class, as
8 all such claims arise out of Defendant's conduct in designing, manufacturing, marketing, advertising,
9 warranting, and selling the Class Beds. All of Plaintiff's claims are typical of the claims of the Class
10 since Plaintiff and all Class members were injured in the same manner by Defendant's uniform
11 course of conduct described herein. Plaintiff and all Class members have the same claims against
12 Defendant relating to the conduct alleged herein, and the same events giving rise to Plaintiff's claims
13 for relief are identical to those giving rise to the claims of all Class members. Plaintiff and all Class
14 members sustained economic injuries including, but not limited to, ascertainable losses arising out of
15 Defendant's course of conduct as described herein. Plaintiff is advancing the same claims and legal
16 theories on behalf of himself and all absent Class members.
17
18

19 49. *Adequacy*: Plaintiff will fairly and adequately protect the interests of the members of
20 the Class and has no interests antagonistic to those of the Class. Plaintiff has retained counsel
21 experienced in the prosecution of complex class actions including, but not limited to, consumer class
22 actions involving, *inter alia*, breaches of warranties, product liability, product design defects, and
23 state consumer fraud statutes.
24

25 50. *Superiority*: A class action is superior to other available methods for the fair and
26 efficient adjudication of this controversy, since individual joinder of all members of the Class is
27 impracticable, and the amount at issue for each Class member would not justify the cost of litigating
28

1 individual claims. Should individual Class members be required to bring separate actions, this Court
2 would be confronted with a multiplicity of lawsuits burdening the court system while also creating
3 the risk of inconsistent rulings and contradictory judgments. In contrast to proceeding on a case-by-
4 case basis, in which inconsistent results will magnify the delay and expense to all parties and the
5 court system, this class action presents far fewer management difficulties while providing unitary
6 adjudication, economies of scale and comprehensive supervision by a single court.
7

8 51. *Manageability*: Plaintiff is unaware of any difficulties that are likely to be encountered
9 in the management of this action that would preclude its maintenance as a class action.

10 52. Defendants have acted, and refused to act, on grounds generally applicable to the
11 Class, thereby making appropriate final equitable relief with respect to the Class as a whole.
12

13 **COUNT I**
14 **BREACH OF EXPRESS WARRANTY, U.C.C. § 2-313**
15 **(By Plaintiff on Behalf of the Nationwide Class, and, in the alternative,**
16 **by Plaintiff Zhang on behalf of the California Subclass)**

17 53. Plaintiff incorporates by reference all preceding paragraphs as though fully set forth
18 herein.

19 54. Plaintiff brings this claim on behalf of himself and on behalf of the Nationwide Class
20 and, in the alternative, on behalf of the California Subclass.

21 55. Defendant is a “merchant” (as defined by CAL. COM. CODE § 2104(1)), and a
22 “seller” (as defined by CAL. COM. CODE § 2103(d)).

23 56. Pursuant to U.C.C. § 2-313(a)(1), “[a]ny affirmation of fact or promise made by the
24 seller to the buyer which relates to the goods and becomes part of the basis of the bargain creates an
25 express warranty that the goods shall conform to the affirmation or promise.”

26 57. The Class Beds are “goods” within the meaning of the UNIFORM COMMERCIAL
27 CODE and relevant state law, including CAL. COM. CODE § 2105(1).
28

1 58. Defendant expressly represented that the bed slats were made out of solid wood.

2 59. This representation formed the basis of the bargain that was reached when Plaintiff
3 and other Class members purchased their Class Beds.

4 60. Defendant breached this express warranty through the acts and omissions described
5 above.

6 61. Plaintiff and other Class members have had sufficient direct dealings with either
7 Defendant or its agents (*e.g.*, dealerships, consumer affairs departments, and technical support) to
8 establish privity of contract between Defendant on one hand, and Plaintiff and each of the other Class
9 members on the other hand. Nonetheless, privity is not required here because Plaintiff and each of the
10 other Class members are intended third-party beneficiaries of contracts between Defendant and their
11 dealers, and specifically, of Defendant's express warranties; the warranty agreements were designed
12 for and intended to benefit the consumer only. Additionally, privity is excused here because Plaintiff
13 and each of the other Class members relied on statements made by Defendant itself in choosing to
14 purchase a Class Bed. As alleged herein, the marketing of the Class Beds was uniform and was
15 controlled and disseminated directly by Defendant.

16 62. Defendant knew that it was unable to provide adequate remedy under the warranty.
17 Defendant was also provided notice of its misrepresentation through its own internal engineering
18 knowledge. Ikea has not remedied its breach.

19 63. Further, Defendant has refused to provide an adequate warranty repair for the Defect,
20 thus rendering the satisfaction of any notice requirement futile.

21 64. The written express warranties fail in their essential purpose because the contractual
22 remedy is insufficient to make Plaintiff and other Class members whole and because Defendant has
23 failed and/or has refused to adequately provide effective remedies within a reasonable time.
24
25
26
27
28

1 65. Accordingly, recovery by Plaintiff and other Class members is not limited to the
2 limited remedy of repair, and Plaintiff, individually and on behalf of the other Class members, seeks
3 all remedies as allowed by law.

4 66. Also, as alleged in more detail herein, at the time that Ikea warranted and sold the
5 Class Beds, it knew that the Class Beds did not conform to the warranty and were inherently
6 defective, and Defendant improperly concealed material facts regarding its Class Beds. Plaintiff and
7 other Class Members were therefore induced to purchase the Class Beds under false pretenses.
8

9 67. Defendant had notice of its breach as alleged above. Additionally, on or about October
10 10, 2023, Plaintiff sent a pre-suit notice letter which Defendant has not responded to.
11

12 68. As a direct and proximate result of Defendant’s breach of its express warranty,
13 Plaintiff and other Class members have been damaged in an amount to be determined at trial.

14 69. Plaintiff, on behalf of himself and the Class, seeks monetary damages, treble damages,
15 costs, attorneys’ fees, and such other and further relief provided by law and equity.
16

17 **COUNT II**
18 **BREACH OF IMPLIED WARRANTY OF MERCHANTABILITY**
19 **(CAL. COM. CODE §§ 2314, 10212)**
20 **(On Behalf of the Nationwide Class or,**
21 **Alternatively, on Behalf of the California Class)**

22 70. Plaintiff realleges and incorporates by reference all preceding allegations as though
23 fully set forth herein.

24 71. Plaintiff brings this claim individually and on behalf of the other members of the
25 Nationwide Class.

26 72. Defendant is a “merchant” (as defined by CAL COM. CODE § 2104(1)), and a
27 “seller” (as defined by CAL. COM. CODE § 2103(d)).
28

1 73. The Class Beds are “goods” within the meaning of the Uniform Commercial Code and
2 relevant state law, including CAL. COM. CODE § 2105(1).

3 74. Defendant was, at all relevant times, the manufacturer, distributor, warrantor, and/or
4 seller of the Class Beds. Defendant knew or had reason to know of the specific use for which the
5 Class Beds were purchased.
6

7 75. Pursuant to CAL. COM. CODE § 2314(1) “a warranty that the goods shall be
8 merchantable is implied in a contract for their sale if the seller is a merchant with respect to goods of
9 that kind.” Goods are merchantable if they are “fit for the ordinary purposes for which such goods are
10 used” and “[c]onform to the promises or affirmations of fact made on the container or label if any.”
11 CAL. COM. CODE § 2314(2)(c), (f).
12

13 76. Defendant provided Plaintiff and other Class members with an implied warranty that
14 the Class Beds and any parts thereof are merchantable and fit for the ordinary purposes for which
15 they were sold. However, the Class Beds are not fit for their ordinary purpose of providing
16 reasonably reliable and safe support for sitting or sleeping at the time of sale of thereafter because,
17 *inter alia*, the Class Beds suffered from the Defect at the time of sale that creates the undue risk of
18 structural collapse. Therefore, the Class Beds are not fit for their particular purpose of providing safe
19 and reliable support for sitting or sleeping.
20

21 77. Defendant impliedly warranted that the Class Beds were of merchantable quality and
22 fit for such use. This implied warranty included, among other things, a warranty that the Class Beds
23 were manufactured, supplied, distributed, and/or sold by Defendant, were safe and reliable for
24 providing support, and would not result in the premature failure of its base.
25

26 78. Contrary to the applicable implied warranties, the Class Beds at the time of sale and
27 thereafter were not fit for their ordinary and intended purpose of providing Plaintiff and other Class
28

1 members with reliable, durable, and safe support. Instead, the Class Beds suffer from a defective
2 design(s) and/or manufacturing defect(s).

3 79. Defendant knew or had reason to know of these material facts, and wrongfully and
4 fraudulently concealed these material facts from Plaintiff and the Class.

5 80. Defendant's actions, as complained of herein, breached the implied warranty that the
6 Class Beds were of merchantable quality and fit for such use.

7 81. Plaintiff and other Class members have had sufficient direct dealings with either
8 Defendant or its agents – such as its stores, consumer affairs departments, and technical support – to
9 establish privity of contract between Defendant on one hand, and Plaintiff and each of the other Class
10 members on the other hand. Nonetheless, privity is not required here because Plaintiff and each of the
11 other Class members are intended third-party beneficiaries of contracts between Defendant and its
12 stores, and specifically, of Defendant's implied warranties. The stores were not intended to be the
13 ultimate consumers of the Class Beds and have no rights under the warranty agreements provided
14 with the Class Beds; the warranty agreements were designed for and intended to benefit the
15 consumers only. Additionally, privity is excused here because Plaintiff and each of the other Class
16 members relied on statements made by Defendant itself in choosing to purchase a Class Bed. As
17 alleged herein, the marketing of the Class Beds was uniform and was controlled and disseminated
18 directly by Defendant.

19 82. Defendant had notice of its breach as alleged above. Additionally, on or about October
20 25, 2023, Plaintiff sent a pre-suit notice letter which Defendant has not responded to.

21 83. Plaintiff, on behalf of himself and the Class, seeks monetary damages, treble damages,
22 costs, attorneys' fees, and such other and further relief provided by law and equity.

23
24
25
26
27 **COUNT III**
28 **VIOLATION OF THE CALIFORNIA UNFAIR COMPETITION LAW**

**(Cal. Bus. & Prof. Code § 17200, et seq.)
(On Behalf of the Nationwide Class or,
Alternatively, on Behalf of the California Class)**

1
2
3 84. Plaintiff realleges and reincorporates by reference all preceding allegations as though
4 fully set forth herein.

5
6 85. Plaintiff brings this claim individually and on behalf of the other members of the
7 Nationwide Class.

8 86. The UCL defines unfair competition to include any “unlawful, unfair or fraudulent
9 business act or practice and unfair, deceptive, untrue or misleading advertising and any act prohibited
10 by Chapter 1 (commencing with Section 17500) of Part 3 of Division 7 of the Business and
11 Professions Code.” Cal. Bus. & Prof. Code § 17201.

12
13 87. Defendant violated the UCL by engaging in unlawful, unfair, and deceptive business
14 acts and practices.

15 88. Defendant is a “person” as defined by Cal. Bus. & Prof. Code § 17201.

16
17 89. Pursuant to Cal. Bus. & Prof. Code § 17204, the Plaintiff named herein, and the
18 members of the proposed Class, has suffered injury in fact and has lost money or property because of
19 the unfair competition set forth herein.

20 90. Ikea’s conduct, as described herein, was and is in violation of the UCL. Ikea’s conduct
21 violates the UCL by, among other things; (a) failing to disclose the existence of the Defect in the
22 Class Beds; (b) marketing and promoting the Class Beds as being free from defect, including the
23 Comb Joints Defect which causes the Class Beds to fail to perform their essential function and
24 creates safety risks; (c) knowingly and intentionally concealing the existence of the Defect in the
25 Class Beds; (d) violating California laws, including the CLRA; and (e) breaching its express and
26 implied warranties.
27
28

1 91. Ikea intentionally and knowingly misrepresented and omitted material facts regarding
2 the Class Beds with intent to mislead Plaintiff and other Class members.

3 92. In purchasing or financing the Class Beds, Plaintiff and other Class members were
4 deceived by Ikea's failure to disclose the Comb Joints Defect found in the Class Beds.
5

6 93. Plaintiff and other Class members reasonably relied upon Ikea's false
7 misrepresentations and omissions. They had no way of knowing that Defendant's representations
8 were false, misleading, and incomplete. As alleged herein, Defendant engaged in a pattern of
9 deception and public silence in the face of a known Comb Joint Defect in the Class Beds. Plaintiff
10 and other Class members did not, and could not, discover Defendant's deception on their own.
11

12 94. Defendant knew or should have known that its conduct violated the UCL.

13 95. Defendant owed Plaintiff and other Class members a duty to disclose the truth about
14 the Comb Joint Defect because the Defect created a safety hazard and Defendant: (a) possessed
15 exclusive knowledge of the Defect; (b) intentionally concealed the Defect from Plaintiff and the
16 Class; and/or (c) made incomplete representations by failing to warn the public or to recall the Class
17 Beds due to the Defect.
18

19 96. Defendant had a duty to disclose the existence of the Defect in the Class Beds because
20 Plaintiff and other Class members relied on Defendant's material misrepresentations and omissions.

21 97. Defendant's conduct proximately caused injuries to Plaintiff and other Class members
22 that purchased or financed the Class Beds and suffered hard as alleged herein.

23 98. Plaintiff and other Class members were injured and suffered ascertainable loss, injury-
24 in-fact, and/or actual damage as a proximate result of Defendant's conduct in that Plaintiff and other
25 Class members incurred costs related to the diminished structural integrity caused by the Defect,
26
27
28

1 including replacement of base boards and service costs, and overpaid for their Class Beds that have
 2 suffered a diminution in value.

3 99. Plaintiff and the Class members are suffering from continuing injuries because Ikea
 4 has failed to issue an adequate remedy for the Defect found in each of the Class Beds. Defendant’s
 5 unlawful acts and practices complained of herein affect the public interest.
 6

7 100. Defendant’s misrepresentations and omissions alleged herein caused Plaintiff and
 8 other Class members to make their purchases or financing of their Class Beds. Absent those
 9 misrepresentations and omissions, Plaintiff and other Class members would not have purchased or
 10 financed their Class Beds, would not have purchased or financed their Class Beds at the prices they
 11 paid, and/or would have purchased or financed less expensive alternative beds that did not suffer
 12 from the Comb Joint Defect and failed to live up to industry standards.
 13

14 101. Accordingly, Plaintiff and other Class members have suffered injury-in-fact, including
 15 lost money or property, as a result of Defendant’s misrepresentations and omissions.
 16

17 102. Plaintiff requests that this Court enjoin further unlawful, unfair, and/or fraudulent acts
 18 or practices by Defendant, and order restitutionary disgorgement of all monies and revenues
 19 generated as a result of such practices, and all other relief allowed under Cal. Bus. & Prof. Code §
 20 17200, including reasonable attorneys’ fees and costs under Cal. Civ. Proc. Code § 1021.5.
 21

22 **COUNT IV**
VIOLATION OF THE CALIFORNIA FALSE ADVERTISING LAW
(Cal. Bus. & Prof. Code § 17500, *et seq.*)
(On Behalf of the Nationwide Class, or,
 23 **Alternatively, on Behalf of the California Class)**
 24

25 103. Plaintiff realleges and incorporates by reference all preceding paragraphs as though
 26 fully set forth herein.
 27
 28

1 104. Plaintiff brings this claim individually and on behalf of the other members of the
2 Nationwide Class.

3 105. Cal. Bus. & Prof. Code § 17500 states:

4 It is unlawful for any . . . corporation . . . with intent directly or indirectly to dispose of real or
5 personal property . . . to induce the public to enter into any obligation relating thereto, to make
6 or disseminate or cause to be made or disseminated . . . from this state before the public in any
7 state, in any newspaper or other publication, or any advertising device, . . . or in any other
8 manner or means whatever, including over the Internet, any statement . . . which is untrue or
misleading, and which is known, or which by the exercise of reasonable care should be
known, to be untrue or misleading

9 106. Ikea caused to be made or disseminated through California and the United States,
10 through advertising, marketing, and other publications, statements that were untrue or misleading,
11 and which were known, or which by the exercise of reasonable care should have been known, to Ikea
12 to be untrue and misleading to consumers, including Plaintiff and Class members.

13 107. Ikea has violated Cal. Bus. & Prof. Code § 17500 because the misrepresentations and
14 omissions regarding the quality, safety, and reliability of the Class Beds and the Defect contained in
15 the Class Beds as well as the associated safety risks and repair costs that result from it as set forth in
16 this Complaint were material and likely to deceive a reasonable consumer.

17 108. Ikea has also violated Cal. Bus. & Prof. Code § 17500 because the misrepresentations
18 and omissions regarding the existence of a repair for the Defect and Defendant's ability and intention
19 to render such a repair as set forth in this Complaint were material and likely to deceive a reasonable
20 consumer.

21 109. Plaintiff and Class members have suffered an injury in fact, including the loss of
22 money or property, as a result of Ikea's unfair, unlawful, and/or deceptive practices. In purchasing or
23 financing their Class Beds, Plaintiff and Class members relied on the misrepresentations and/or
24 omissions of Ikea with respect to the quality, safety, and reliability of the Class Beds as well as the
25
26
27
28

1 existence of a repair for the Defect. Honda’s representations turned out to be false because as a result
2 of the Defect that could result in structural failure and collapse while using the Class Beds under
3 normal conditions, the Class Beds are unsafe, unreliable, and not of high quality. Additionally, no
4 permanent and reliable repair exists for the Defect. Had Plaintiff and Class members known this, they
5 would not have purchased or leased their Class Beds and/or paid as much for them.
6

7 110. Accordingly, Plaintiff and Class members overpaid for their Class Beds and did not
8 receive the benefit of their bargain.

9 111. All of the wrongful conduct alleged herein occurred, and continues to occur, in the
10 conduct of Ikea’s business. Ikea’s wrongful conduct is part of a pattern or generalized course of
11 conduct that is still perpetuated and repeated, both in the state of California and nationwide.
12

13 112. Plaintiff, individually and on behalf of the Class, request that this Court enter such
14 Orders or judgments as may be necessary to restore to Plaintiff and Class members any money Ikea
15 acquired by unfair competition, including restitution and/or restitutionary disgorgement and all other
16 relief allowed under Cal. Bus. & Prof. Code § 17500, including reasonable attorneys’ fees and costs
17 under California Cal. Civ. Proc. Code § 1021.5.
18

19 **COUNT V**
20 **Violation of California’s Consumer Legal Remedies Act (the “CLRA”)**
21 **Cal. Civ. Code § 1750, *et seq.***
22 **(On behalf of the Nationwide Class and California Subclass)**

23 113. Plaintiff realleges and incorporates by reference all preceding paragraphs as though
24 fully set forth herein.

25 114. Plaintiff brings this cause of action individually and on behalf of the members of the
26 Nationwide Class and California Subclass.

27 115. Defendant is a “person” within the meaning of California Civil Code sections 1761(c)
28 and 1770 and provided “goods” within the meaning of sections 1761(a) and 1770.

1 116. Defendant's acts and practices, as alleged in this complaint, violate California Civil
2 Code sections 1770(a)(5), (7) and (9) because they include unfair and deceptive acts and practices in
3 connection with transactions—the sale of defective countertop Class Beds. In violation of the CLRA,

4 Ikea:

5 117. Represented that the Class Beds had characteristics, uses, and benefits they do not
6 have;
7

8 118. Represented that the Class Beds are of a standard, quality, or grade when in fact they
9 are not; and

10 119. Advertised the Class Beds with intent not to sell them as advertised.

11 120. Through its design, development, and pre-release testing of the display, as well as
12 through consumer complaints, Ikea knew that the Class Beds' glass doors were defective and prone
13 to explosion.
14

15 121. Ikea was under a duty to disclose that the Class Beds are defective because it had
16 superior knowledge of the Defect—stemming from repairs, complaints made directly to Ikea, online
17 complaints, its quality control and pre-release testing, as well as online reputation management —and
18 because it made partial, materially misleading representations about the Class Beds' high quality and
19 versatile features.
20

21 122. Ikea had ample means and opportunities to disclose to Plaintiff and Class Members
22 that the Class Beds are defective, including through advertisements, on external packaging, and
23 during the Class Beds' setup process. Despite its exclusive knowledge and opportunities to disclose
24 the Class Beds' defective nature, Ikea failed to disclose the Defect to Plaintiff and Class Members
25 either prior to purchase or before Plaintiff and Class Members' respective buyer's remorse periods
26 expired.
27
28

1 123. Ikea’s misrepresentations and omissions were material. Had Plaintiff and Class
2 Members known that the Class Beds were defective, they would not have purchased the Class Beds,
3 would not have purchased them at the prices they did, or would have returned their Class Beds during
4 their respective buyer’s remorse periods.

5
6 124. Under California Civil Code section 1782(a), on their own behalf and on behalf of the
7 Class, Plaintiff sent notices to Ikea on October 25, 2023, via letter sent by certified mail to Ikea’s
8 principal place of business, advising Ikea of its violations and that it must correct, replace, or
9 otherwise rectify the goods alleged to be in violation. Ikea failed to correct its business practices or
10 provide the requested relief within 30 days. Accordingly, Plaintiff seeks monetary damages under the
11 CLRA.
12

13 125. Plaintiff was injured by Ikea’s CLRA violations. As a result, Plaintiff is entitled to
14 actual damages in an amount to be proven at trial, reasonable attorney’s fees and costs, declaratory
15 relief and punitive damages.
16

17 **COUNT VI**
18 **VIOLATIONS OF THE SONG-BEVERLY**
19 **CONSUMER WARRANTY ACT -**
20 **(Cal. Civ. Code §§ 1791.2 & 1793.2(D))**

21 126. Plaintiff realleges and incorporates by reference all preceding paragraphs as though
22 fully set forth herein.

23 127. Plaintiff brings this claim on behalf of himself and on behalf of the members of the
24 California Subclass.

25 128. Plaintiff and the California Subclass members are “buyers” within the meaning of Cal.
26 Civ. Code § 1791(b).

27 129. The Class Beds are “consumer goods” within the meaning of Cal. Civ. Code §
28 1791(a).

1 130. Ikea is a “manufacturer” of the Class Beds within the meaning of Cal. Civ. Code §
2 1791(j).

3 131. The California plaintiff and the other Class members bought new Class Beds
4 manufactured by Ikea. Ikea made express warranties to California Plaintiff and the other Class
5 members within the meaning of Cal. Civ. Code §§ 1791.2 and 1793.2, as described above. These
6 warranties became part of the basis of the parties’ bargain. Accordingly, Ikea’s warranties are express
7 warranties under state law.
8

9 132. Plaintiff and California Subclass members experienced the Defect within the warranty
10 period. Despite the existence of warranties, Ikea failed or refused to fix the Comb Joint Defect.
11

12 133. Plaintiff and California Subclass members put Ikea on notice of the Defect and gave
13 Ikea opportunity to remedy the Defect. Ikea did not promptly replace or buy back the Class Beds of
14 Plaintiff and the other Class members.

15 134. Pursuant to Cal. Civ. Code §§ 1793.2 & 1794, Plaintiff and the other California
16 Subclass members are entitled to damages and other legal and equitable relief including, at their
17 election, the purchase price of their Class Beds, or the overpayment or diminution in value of their
18 Class Beds.
19

20 **COUNT VII**
21 **VIOLATIONS OF THE SONG-BEVERLY ACT -**
22 **BREACH OF THE IMPLIED WARRANTY OF MERCHANTABILITY**
(Cal. Civ. Code §§ 1792, 1791.1, *et seq.*)

23 135. Plaintiff realleges and incorporates by reference the preceding paragraphs as if fully
24 set forth herein.

25 136. Plaintiff brings this claim on behalf of himself and on behalf of the members of the
26 California Subclass against Ikea.
27
28

1 137. At all relevant times hereto, Ikea was the manufacturer, distributor, warrantor, and/or
2 seller of the Class Beds. Ikea knew or should have known of the specific use for which the Class
3 Beds were purchased.

4 138. Ikea provided Plaintiff and the California Subclass members with an implied warranty
5 that the Class Beds, and any parts thereof, are merchantable and fit for the ordinary purposes for
6 which they were sold. The Class Beds, however, are not fit for their ordinary purpose because, inter
7 alia, the Class Beds suffered from an inherent Comb Joint Defect at the time of sale.

8 139. The Class Beds are not fit for the purpose of providing safe and reliable support
9 because of the Defect.
10

11 140. Ikea impliedly warranted that the Class Beds were of merchantable quality and fit for
12 such use. This implied warranty included, inter alia, the following: (i) a warranty that the Class Beds
13 were manufactured, supplied, distributed, and/or sold by Ikea were safe and reliable for providing
14 support and would not prematurely and catastrophically fail; and (ii) a warranty that the Class Beds
15 would be fit for their intended use – providing safe and reliable support – while the Class Beds were
16 being used.
17

18 141. Contrary to the applicable implied warranties, the Class Beds were not fit for their
19 ordinary and intended purpose. Instead, the Class Beds are defective, including, but not limited to, the
20 Comb Joint Defect.
21

22 142. Ikea's actions, as complained of herein, breached the implied warranty that the Class
23 Beds were of merchantable quality and fit for such use in violation of California Civil Code §§ 1792
24 and 1791.1.
25

26 **VI. PRAYER FOR RELIEF**
27
28

1 WHEREFORE, Plaintiff, individually and on behalf of members of the Class, respectfully prays
2 that the Court:

3 A. Issue an Order certifying this action as a class action pursuant to Rule 23 of the FEDERAL
4 RULES OF CIVIL PROCEDURE; declaring that Plaintiff is a proper Class representative; and
5 appointing Plaintiff's counsel as Class Counsel;
6

7 B. Award Plaintiff and Class members damages, restitution, and disgorgement in an amount to
8 be determined at trial;

9 C. Order appropriate injunctive and/or declaratory relief, including, but not limited to, an Order
10 that requires Defendant to repair, recall, and/or replace the Class Beds and to extend the applicable
11 warranties to a reasonable period of time, or, at a minimum, to provide Plaintiff and Class members
12 with appropriate curative notice regarding the existence and cause of the Defect;
13

14 D. Award to Plaintiff the costs and disbursements of the action, along with reasonable attorneys'
15 fees, costs, and expenses, including pursuant to California Code of Civil Procedure § 1021.5;

16 E. Award pre- and post-judgment interest at the maximum legal rate; and

17 F. Grant all such other relief as is just and proper.
18

19 **DEMAND FOR JURY TRIAL**

20 Plaintiff demands a jury trial on all claims so triable.

21 DATED: March 15, 2024

Respectfully submitted,

22
23
24 /s/ Robert Mackey

Robert Mackey

LAW OFFICES OF ROBERT MACKEY

16320 Murphy Road

Sonora, CA 96370

Telephone: (412) 370-9110

26
27 *bobmackeyesq@aol.com*
28

1
2
3
4
5
6
7
8
9
10
11
12
13
14
15
16
17
18
19
20
21
22
23
24
25
26
27
28

Nicholas A. Migliaccio *
Jason S. Rathod *
MIGLIACCIO & RATHOD LLP
412 H St. NE, Suite 302
Washington, D.C. 20002
Telephone: (202) 470-3520
Facsimile: (202) 800-2730
nmigliaccio@classlawdc.com
jrathod@classlawdc.com

Attorneys for Plaintiff and the Proposed Class

ClassAction.org

This complaint is part of ClassAction.org's searchable class action lawsuit database and can be found in this post: [Ikea's Hemnes, Brimnes Daybed Frames Are Less Sturdy Than Advertised, Class Action Claims](#)
